

Railway Depot Equipment Chockblock Testing Machine



ULBRICH

www.ulbrich-group.com

Brake testing machine for testing of calliper and chockblock units

Usually, either calliper or block brake units are used for braking train carriages (rolling stock). They are a compact, mechanically independent and a combination of the conventional sub-assemblies: brake cylinders, slack adjusters and brake pad holders. In some instances they are equipped with add-on modules such as spring mechanisms.

Clamp and calliper brakes are available in various construction designs. Essentially all perform the same function and usually have the same connecting dimensions. Apart from additional functions, there is a difference in the design of the brake mount and the position of the mounting thread bores.

Each test program contains all the necessary electrical and pneumatic settings. No manual intervention is required during the testing sequence. The programs can be edited and created independently. The content and sequence of the program steps as well as times, pressures and forces can be adapted to job. The expected values are output and stored as IO or NIO in the tabular test report.

The test programs for block and calliper brake units are largely identical - but can be parameterised and retrieved specifically for the type of testing.

The following tests are possible automatically:

- Checking of the adjuster
- Checking of the spring-loaded brake
- Checking of the emergency release device of the spring-loaded brake
- Checking of the service brake
- Sealing test of the service brake
- High pressure sealing test
- Spring-loaded brake sealing test

In addition to the measured data and test results, the following information is stored:

- Type designation of the BU (brake unit)
- Serial number of the BU
- Type designation of the spring mechanism
- Serial number of the spring mechanism
- Date and time of testing
- Personnel number and/or name of the operator
- Order number of the test

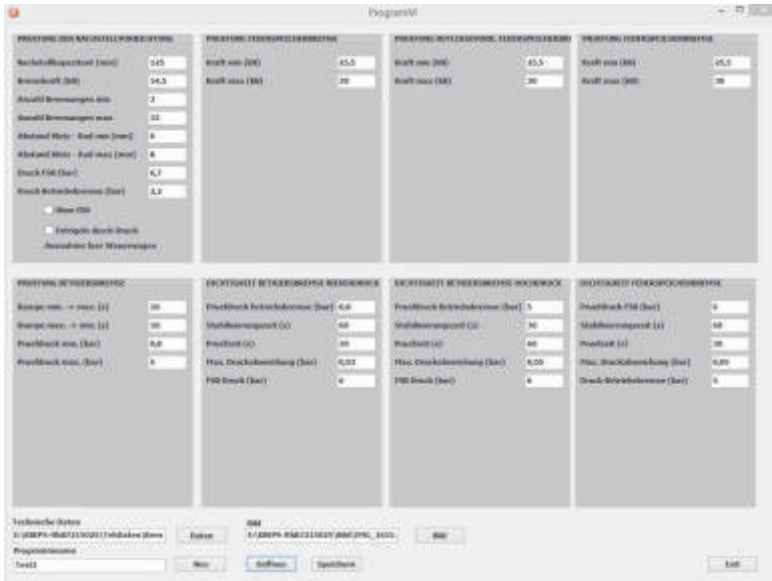

Programming window:

Here, the parameters of the respective tests are defined. Program management allows you to save and edit the programs.

When a program has been selected, technical data and image must be compared with the test item. After pressing OK, the predefined program loads and the test sequence can be started.

Images and data stored in the program allow a visual control of the built-up CBU (chockblock unit) and a comparison between the set-up and the actual set-up.

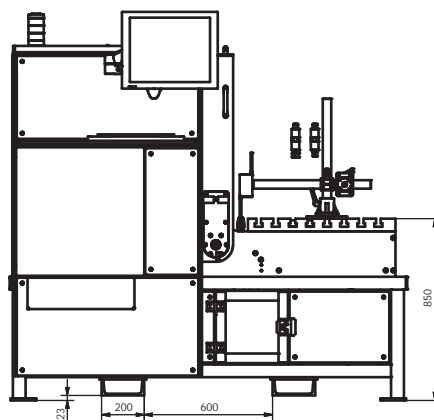
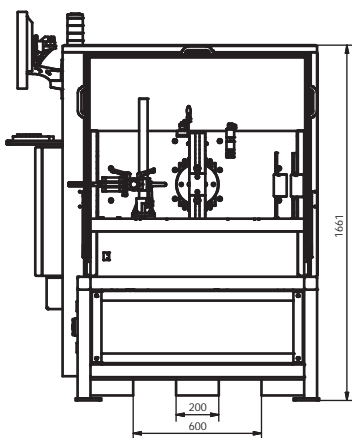

Length:	1830 mm
Width:	1120 mm
Height:	2000 mm
Weight:	1700 kg
Installation Power:	1 kW

ULBRICH

www.ulbrich-group.com



Brake testing machine with a fixture for a chockblock unit



Brake testing machine with fixtures for calliper brakes

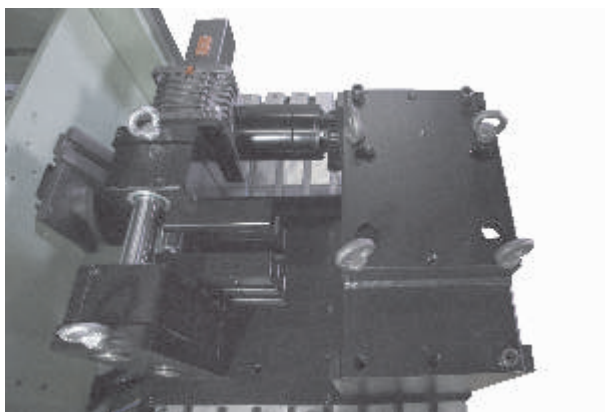



Puffer Testing Machine

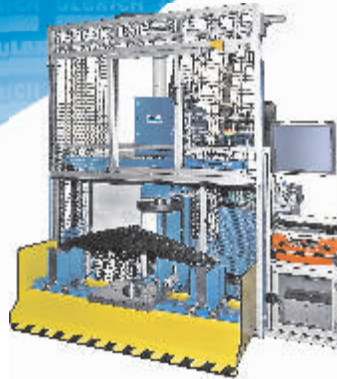

Spring Testing Machine

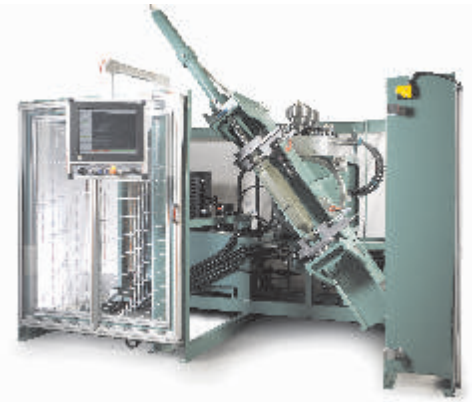

Shock Absorber Testing Machine

Machines for testing assembling & joining

ULBRICH

Competence in joining and testing machines, as well as in hydraulic solutions

We are a Privately owned Austrian Engineering company with Sister companies operating throughout Central and Eastern Europe.

Our main focus is based on the design, construction and the distribution of :

Hydraulic Press and Test Equipment

Hydraulic Components

Hydraulic Systems

Our goal is to provide customers with Test and Production equipment that enable our customers to sink their production costs and increase efficiency, quality and ultimately provide our customers with a significant competitive advantage.

In addition to our standard machinery we also work together with our customers to provide bespoke special hydraulic machines and system solutions based on their unique specifications.

Please visit us at our website



Press fit and analysis units

ULBRICH

www.ulbrich-group.com



Press fit and analysis units

Maschinen zum Prüfen Montieren & Fügen

ULBRICH

Kompetenz in Füge- und Prüfmaschinen sowie Hydraulik

Wir sind ein Familienbetrieb mit Stammsitz in Österreich und diversen Tochterbetrieben bzw. Niederlassungen in Zentral- und Osteuropa.

Wir beschäftigen uns – unter anderem – mit der Produktion und dem Vertrieb von:

Füge und Prüfmaschinen wie z.B. Feder-, Stoßdämpfer- und Pufferprüfmaschinen für die Bahnindustrie

Füge- und Prüfmaschinen für die Automobilindustrie

Ziel unserer Tätigkeit ist es, die Produktivität, Prozesssicherheit und Wettbewerbsfähigkeit unserer Kunden zu stärken.

Neben Serien Prüf- und Fügemaschinen erarbeiten wir gemeinsam mit unseren Kunden hydraulische Sondermaschinen und Hydraulikanlagen für deren spezifische Bedürfnisse.

Bitte besuchen Sie uns auf unserer Webseite

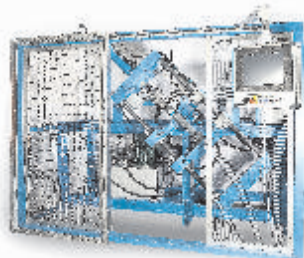

Spring and Shock Absorber Testing Machine



Chockblock Testing Machine



Central Coupler Testing Machine

A – 2512 Tribuswinkel
Josefsthalerstr. 34
Tel.: +43/2252/802 13
Fax: +43/2252/806 59
office@ulbrich.at
www.ulbrich.at

D – 795 39 Lörrach
Im Vogelsang 10
Tel.: +49/7621/162 021
Fax: +49/7621/162 022
info@ulbrich-maschinenbau.de
www.ulbrich-maschinenbau.de

CZ – 251 68 Sulice
Zelivec 344
Tel.: +420/323 673 046
Fax: +420/323 673 047
ulbrich@ulbrich.cz
www.ulbrich.cz

H – 2038 Soskut
Ipari Park 063/19
Tel.: +36 23 560 017
Fax: +36 23 560 018
office@ulbrich.hu
www.ulbrich.hu

SI – 2367 Vuzenica
Sv. Vid 26
Tel.: +386/2/88 79 910
Fax: +386/2/88 79 919
info@ulbrich.si
www.ulbrich.si

SK – 823 62 Bratislava
Revolucna 23
Tel.: +421/2/434 240 16
Fax: +421/2/432 959 83
bratislava@ulbrich.sk
www.ulbrich.sk