

- May be used as accumulator charging valve
- For unloading a high flow – low pressure pump to tank.

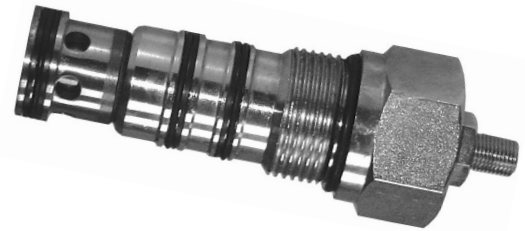
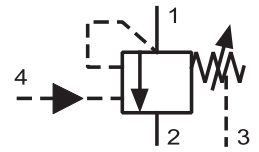

Functional Description

The valve consists of a ball control stage with a common drain into the storage tank, a main stage with a gate valve and a switching stage consisting of a bushing and a control gate valve. It is built-in in a secondary line in view of the feeding line. At the same time connections (1) and (4) are connected to the feeding line however they are separated mutually with the use of a one-way valve. For channel (1) on the side of the pump and channel (4) on the side of the system see page No 4.

The pressure in channel (1) acts through the nozzle hole in the longitudinal axis of the main gate valve also on its side loaded by the spring and through another nozzle hole in the switching stage to the control valve ball. As soon as this pressure exceeds a preset value of the spring force the ball is lifted from its seat and the control oil flows out to the storage tank. As a result of pressure difference the main gate valve is shifted against weak spring and the flow into the side channel (2) is released in this way.

The system pressure in channel (4) acting through the nozzle hole to the control gate valve prevents the control, stage from being shut off. The action of this pressure results in shifting the control gate valve in the direction against the ball of the control stage and in maintaining the ball in the lifted position from the seat. As soon as the system pressure drops to a value of 85% corresponding to the percentage to a ratio of areas of the control stage valve ball seat and the control gate valve the control stage and the main stage are shut off again and a new cycle can start.

As for appropriate basic surface finish the external parts are zinc coated.

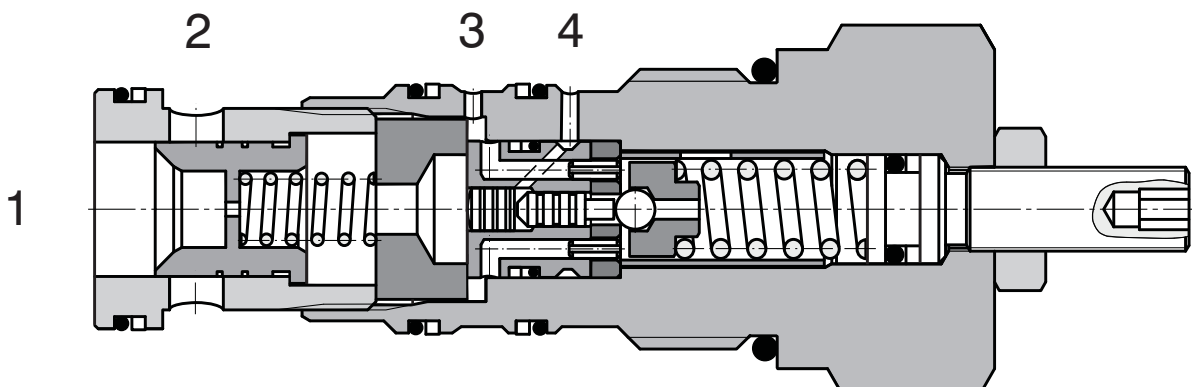

Ordering Code

SUD6A-V4/I

**Pilot Operated Priority
Unloading Valve**

no designation

**Seals
NBR**

Adjustable pressure

30 - 200 bar
150 - 350 bar

20
35

Technical Data

Cavity		1-5/16-12 UNS
Maximum flow	L/min	200
Max. pressure	bar	350
Differential unload/reload	%	10 - 15
Hydraulic fluid		Hydraulic oil (HM, HV) according to DIN 51524
Fluid temperature range	°C	-20 ... +90
Viscosity	mm ² /s	20 ... 400
Maximum degree of fluid contamination		According to ISO 4406 (1999), Class 21/18/15
Weight	kg	0.74
Maximum valve tightening torque in valve body or in control block	Nm	100 ⁺²
Mounting position		any

p-Q Characteristics

Measured at $v = 40 \text{ mm}^2/\text{s}$

Typical valve performance

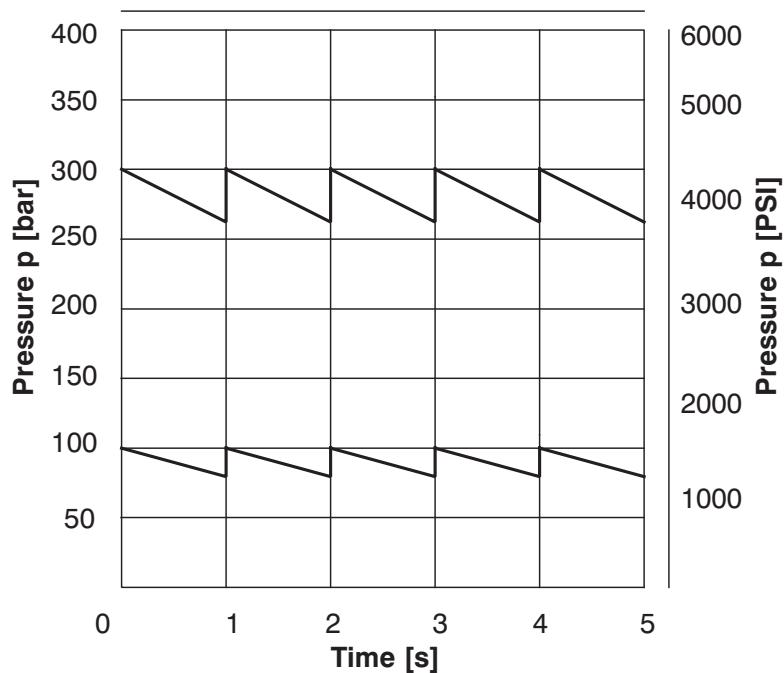

Valve Bodies

Measurements in millimeters

ISO A

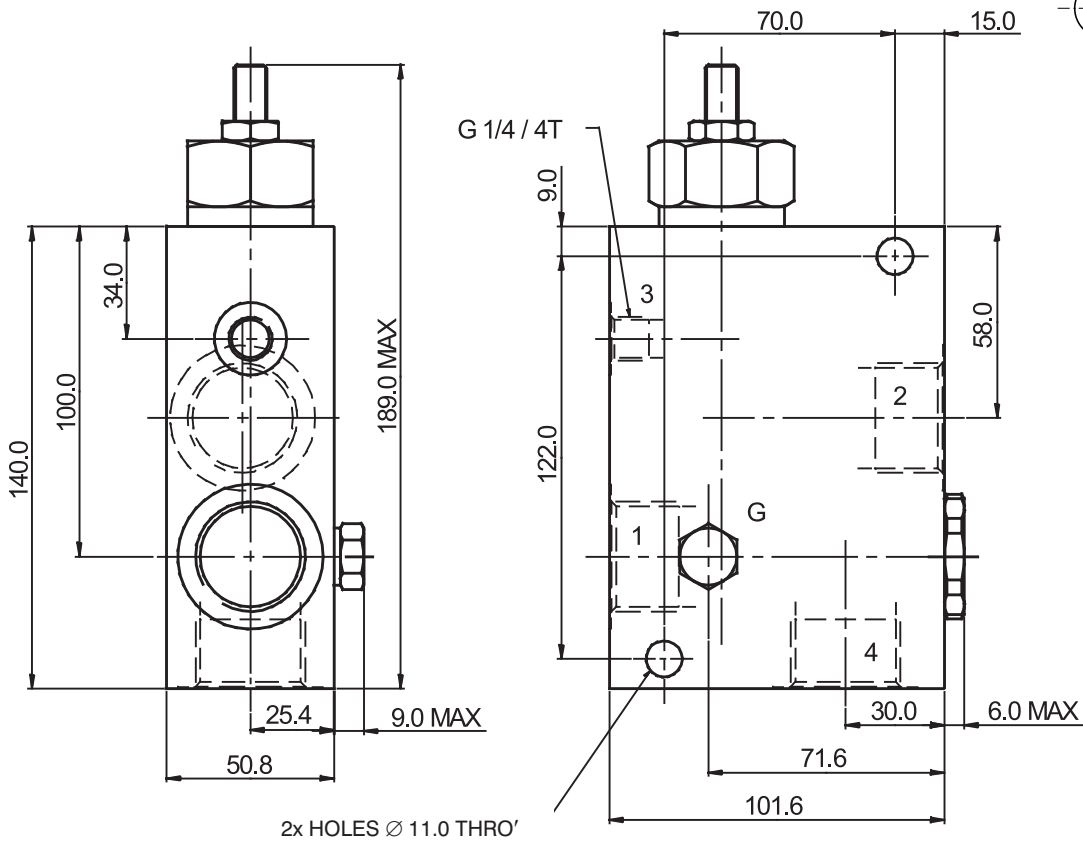

2x HOLES Ø 11.0 THRO'

Body without valve			
Material	Ports	Port size	Type code
Aluminium	1, 2, 4	G1	SB-V4-0109AL
	3	G1/4	
	1, 2, 4	SAE 16, 1-5/16-12	SB-V4-0110AL
	3	SAE 6, 9/16-18	
Steel	1, 2, 4	G1/2	SB-V4-0109ST
	3	G1/4	
	1, 2, 4	SAE 16, 1-5/16-12	SB-V4-0110ST
	3	SAE 6, 9/16-18	

The use of aluminium bodies is limited to a maximum operating pressure of 210 bar.

Spare Parts

Seal kits on request.

Caution!

- The packing foil is recyclable.
- The technical information regarding the product presented in this catalogue is for descriptive purposes only. It should not be construed in any case as a guaranteed representation of the product properties in the sense of the law.

ARGO-HYTOS s.r.o. CZ - 543 15 Vrchlábí
 Tel.: +420-499-403111, Fax: +420-499-403421
 E-mail: sales.cz@argo-hytos.com
 www.argo-hytos.com