

- 2/2 way cartridge valves solenoid operated with spool direction
- Manual override
- No spool sticking by too high tightening torque
- High transmitted power

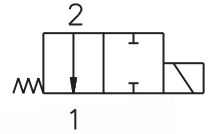

Functional Description

The directly operated 2/2 way solenoid actuated spool valve controls in the first line the start and stop function of the oil flow. The valve consists of the valve body (1), control spool (2), return spring (3), cartridge with actuating system (4) and of the solenoid coil (7) that is mounted on the actuating system. The valve bushing is screwed into the cartridge part (4).

The valve bushing is fixed in the cartridge by a wire ring (5) and sealed with the seal ring (6). Separation of the valve bushing and the cartridge prevent transmitting the stresses, which could be caused by too high tightening torques. The DC solenoid coils can be delivered for 12 V and 24 V supply voltages. For AC applications 120 V/ 60

Hz or 230 V/ 50 Hz. With the high power solenoid coils in AC variants, the rectifiers are integrated directly in the connector. By loosening the fixing nut (8), the solenoid coil can be replaced or turned in the range of 360°. The valve body is zinc coated.

Note:

The valves are supplied without solenoids coils. The solenoid coil, the terminal box and the housing body for line mounting have to be ordered separately.

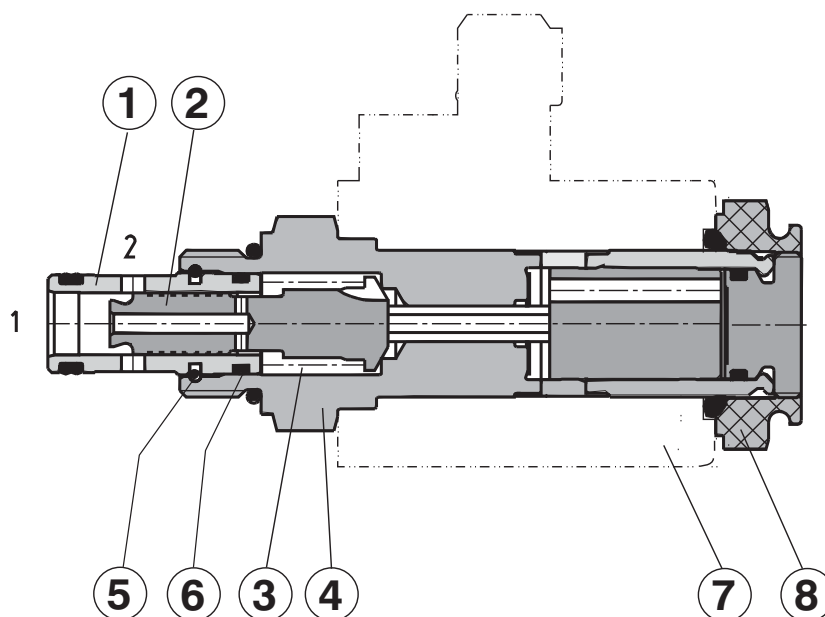

Ordering Code

SD2E-A2 /

**2/2 Way Solenoid Operated
Directional Control Valve Spool
3/4-16UNF**

**No designation
V**

**Seals
NBR
FPM (Viton)**

High performance H

**No designation
M2
M5
M9**

**Manual override
standard
covered with rubber boot
socket head screw
without manual override**

Description
Refer to the table with functional symbols

Solenoid coil, terminal box and body for line mounting have to be ordered separately. For selection of solenoid coil and terminal box type use catalogue HA 8007. For selection of valve body for in-line mounting use catalogue HA0018.

Functional Symbols

Designation	Symbol	Interposition	Designation	Symbol	Interposition
2111			2112		

Manual Override

Dimensions in millimeters (inches)

No designation - standard

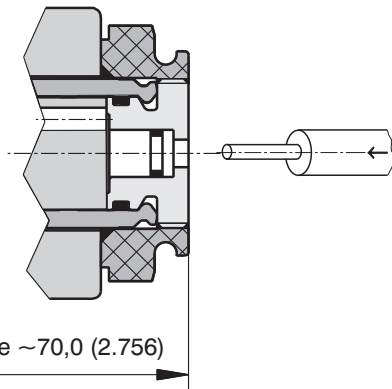

Designation M9 - without manual override

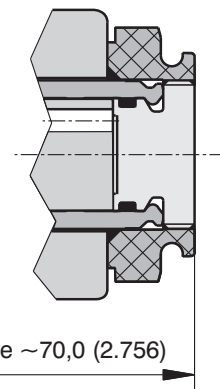

Designation M2 - covered with rubber boot

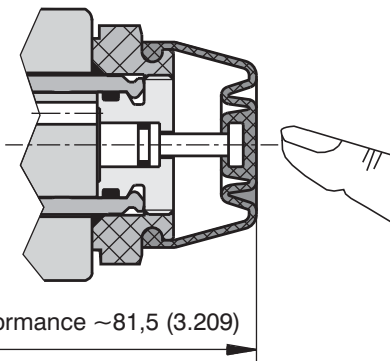

Designation M5 - with socket head screw 2.5 (0.098)

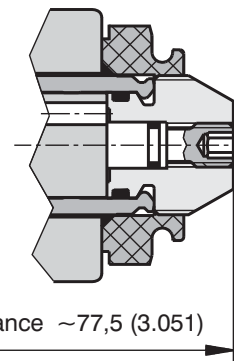

Technical Data

Valve size	A2	
Cartridge cavity	3/4-16 UNF-2A	
Maximum flow	L/min (GPM)	30 (7.9)
Max. operating pressure	bar (PSI)	350 (5076)
Pressure drop	bar (PSI)	see Δp -Q characteristics
Hydraulic fluid	Hydraulic oils of power classes (HL, HLP) to DIN 51524	
Coil groups ¹⁾	C19B	
Fluid temperature range	°C (°F)	-20 ... 80 (-4 ... 176)
Ambient temperature, max.	°C (°F)	-20 ... 80 (-4 ... 176)
Viscosity range	mm ² /s (SUS)	10 ... 500 (49 ... 2450)
Maximum degree of fluid contamination	Class 21/18/15 according to ISO 4406	
Permissible rated voltage variation	%	AC, DC ± 15
Max. switching frequency	1/h	15 000
Duty cycle	%	100
Enclosure type to EN 60529 ¹⁾	IP 67 (IP 65)	
Service life	cycles	10 ⁷
Valve tightening torque	Nm (lbf.ft)	30+2 (22.127+1.475)
Plastic nut tightening torque	Nm (lbf.ft)	3+1 (2.213+0.738)
Weight	kg(lbs)	0,20 (0.44)
Mounting position	unrestricted	
Valve body (data sheed HA 0018)	SB-A2	

¹⁾ see data sheet coils HA 8007

p-Q Characteristic

Δp -Q Characteristic

Measured at $v = 32 \text{ mm}^2/\text{s}$ (156 SUS)

Operating limits for hydraulic power transferred by the directional valve.
For respective spool type - see functional symbols.

Oil 80 °C (176 °F) / Ambient temperature 50 °C (122 °F)
Voltage Un -10% [V] 24 VDC

Pressure drops related to flow rate.

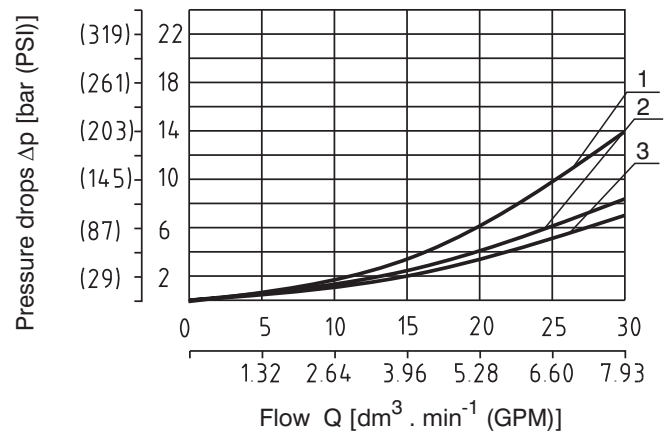
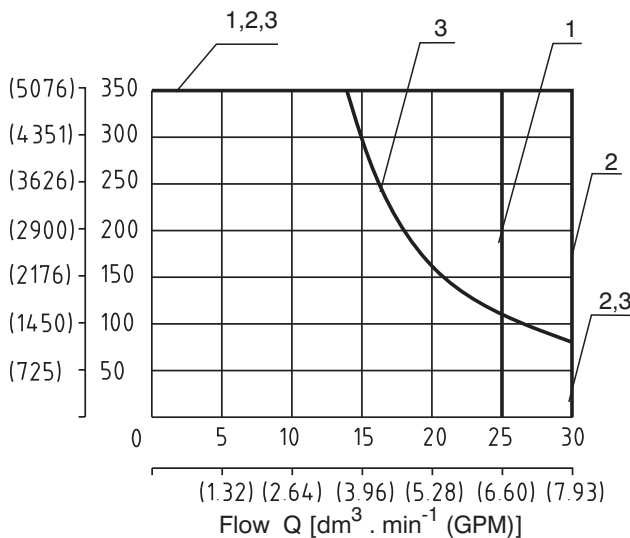

Type of the Solenoid Coils

Dimensions in millimeters (inches)

Example of most frequent coil types.

For complete range of valve coils with technical informatik about voltage, enclosure type, terminal box please afer to coil data sheet HA 8007. *Use the terminal box with rectifier!

Coil example	Solenoid	Connector	Type code
<p>Type E1</p>	12 VDC	EN 175301-803-A	C19B-01200E1-7,1NA
	24 VDC	EN 175301-803-A	C19B-02400E1-28,8NA
	12 VDC	AMP Junior Timer	C19B-01200E3-7,1NA
	24 VDC	AMP Junior Timer	C19B-02400E3-28,8NA
	120 VAC	EN 175301-803-A with integrated rectifier	C19B-12060E5-527NA
	230 VAC	EN 175301-803-A with integrated rectifier	C19B-23050E5-2065NA
	120 VAC	EN 175301-803-A (with rectifier)	C19B-10600E1-527NA*
	230 VAC	EN 175301-803-A (with rectifier)	C19B-20500E1-2065NA*

Valve Dimensions

Dimensions in millimeters (inches)

Cavity

Standard manual override

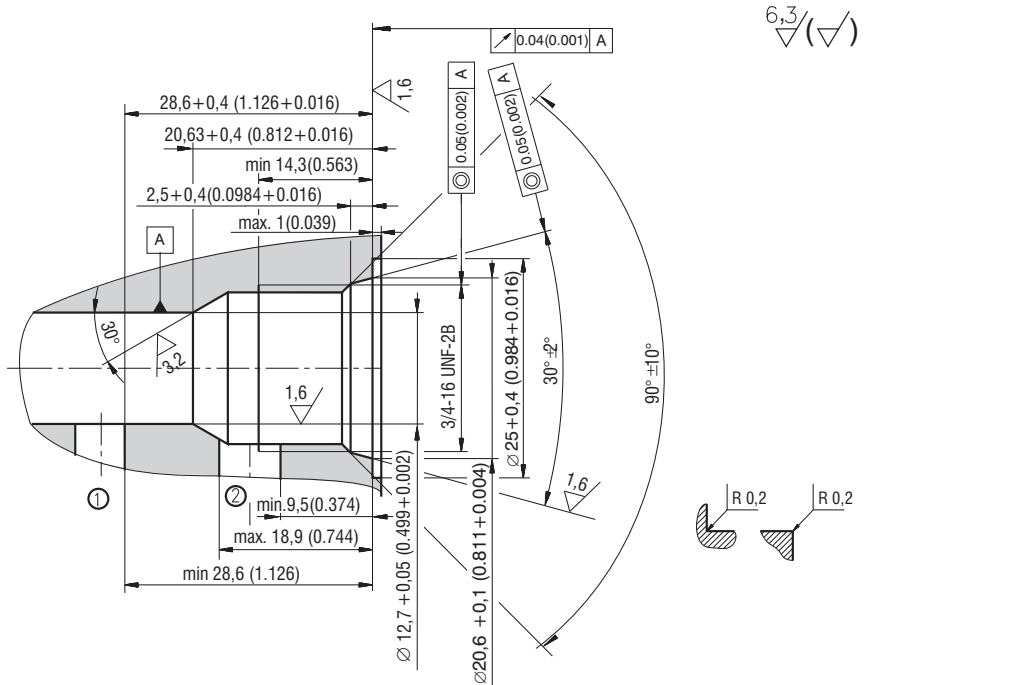

Seal kit - see Spare Parts
 1. Dualseal - PU
 2. O-ring

Spare Parts

Dimensions in millimeters

Seal kit			Ordering number (kit)
Dualseal - PU	O-ring - NBR	O-ring - Viton	
10,3 x 12,7 x 3,1 (1pc.)	17 x 1,8 (1pc.)	-	20776700
10,3 x 12,7 x 3,1 (1pc.)	-	17,17 x 1,78 (1pc.)	17014300
Type of nut			
Standard nut			20777000
Nut M2			20777600

Caution!

- The packing foil is recyclable.
- The technical information regarding the product presented in this catalogue is for descriptive purposes only. It should not be construed in any case as a guaranteed representation of the product properties in the sense of the law.

ARGO-HYTOS s.r.o. CZ - 543 15 Vrchlaví
 Tel.: +420-499-403 111
 E-mail: info.cz@argo-hytos.com
 www.argo-hytos.com